

# THORN

## Contrast LED and Qba LED

Advanced architectural floodlighting  
combining practicality and creativity





Which LED floodlight gives designers exceptional flexibility in the specification of wall washing illumination?

**Qba LED**

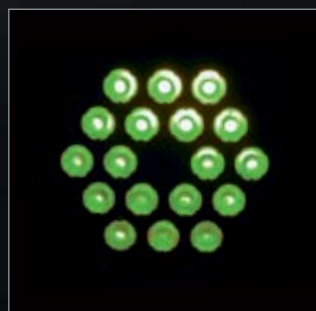
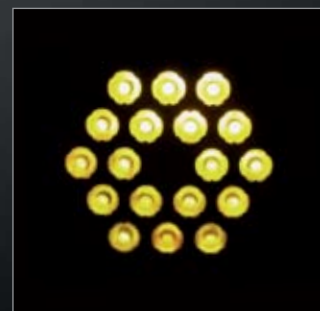
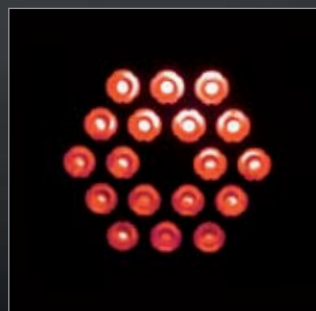



Which LED floodlight has the power to project light up to 30m, yet can produce a variety of precise beam distributions?

**Contrast LED**

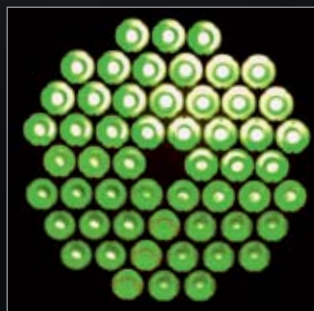
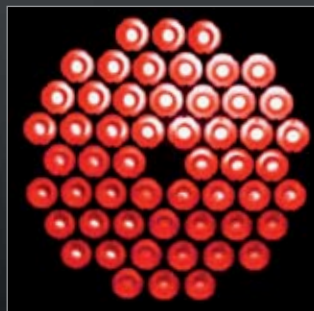

## Qba LED

Engineered for long life, and highly energy efficient, Qba LED offers a choice of colours and controls which enables creative lighting schemes to be implemented quickly and easily.

All Qba LED floodlights can easily be combined with other Qba products, allowing existing installations to be augmented with confidence. Similarly, new projects can combine any Qba luminaires to leverage the product range's uniform light shapes and outputs.

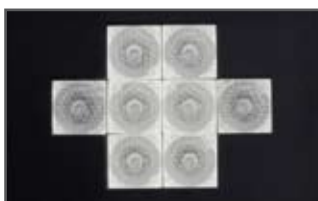

Efficient LEDs for wall washing applications:

- 18 LEDs for monochromatic versions (from +/- 5.6° to 6.6° beam)
- 8 multichip LEDs for the RGB version (12° beam) for better colour mixing

IP66/IK08 floodlight

Easy to combine with conventional Qba floodlights

DMX connection card integrated for the RGB version

Integral gear for all versions



Additional knockout for through wiring (available on request)

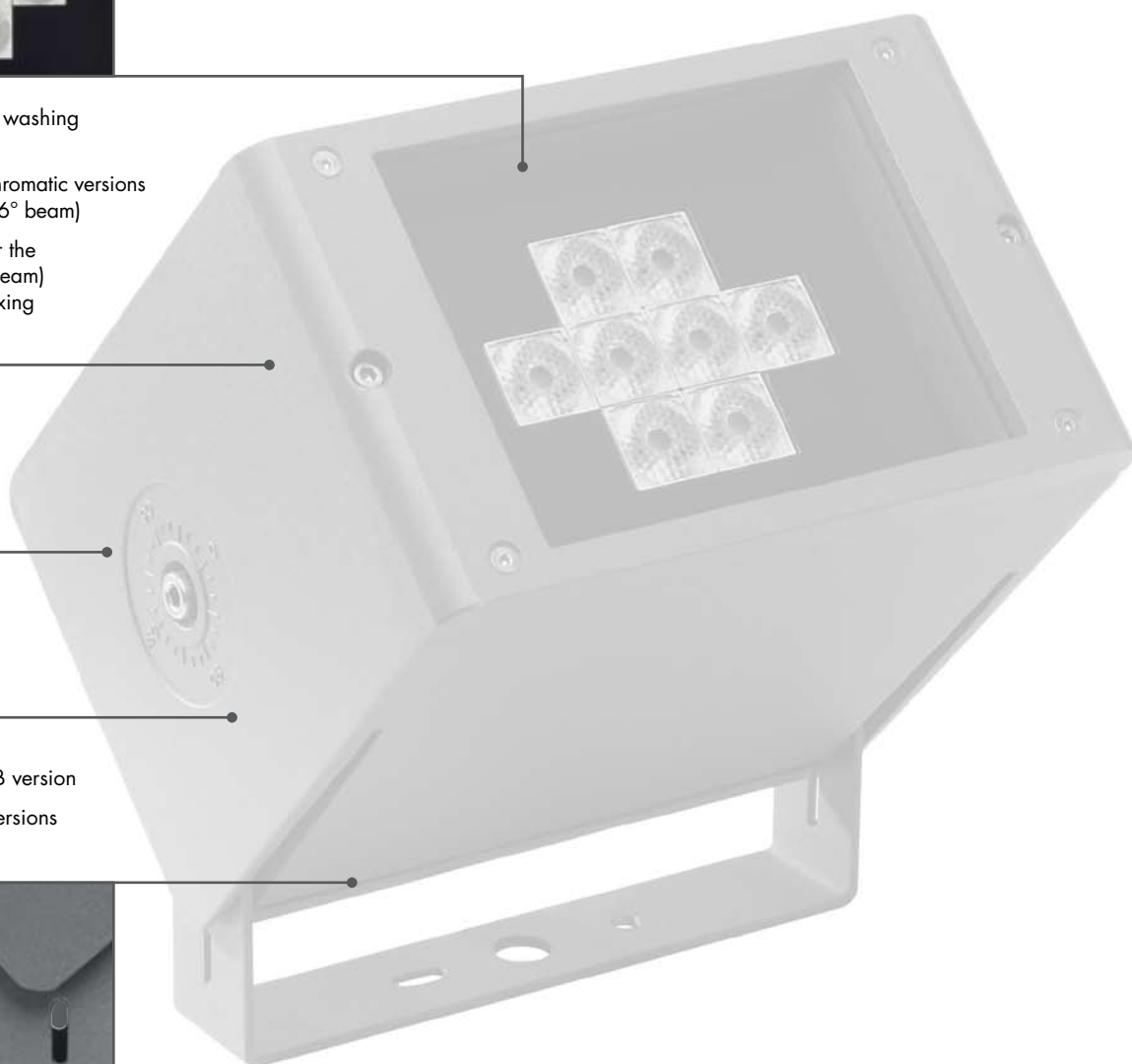

# Contrast LED

The newest addition to Thorn's versatile range of floodlighting fittings, Contrast LED is ideal for use on architectural features and decorative areas. It produces exciting lighting and coloured effects without wasteful spillage onto surrounding details.



Using the Contrast size R0 front frame, the Contrast LED is compatible with all existing accessories (except honeycomb louvre)



Distinctly styled, ultra-modern design with heat dissipation fins to maximise heat transfer and to ensure the life time of the LEDs



Intensive LED technology for efficient light beam ( $\pm 4^\circ$ )

- 54 LEDs for monochromatic versions
- 36 LEDs for RGB and RGBA versions

Slim circular shape for easy integration

IP65/IK08 floodlight body



A Gore-Tex® screw-in vent constantly allows the floodlight to breathe with changing environmental conditions, eliminating condensation and ensuring an IP65 seal

Pre-wired floodlight for easy installation



IP66/IK08 remote connection box with self retaining screws

## Performance, Efficiency and Comfort (PEC) – for a better lit environment

Contrast LED and Qba LED evoke the spirit of Thorn Lighting's dynamic, results-orientated PEC programme

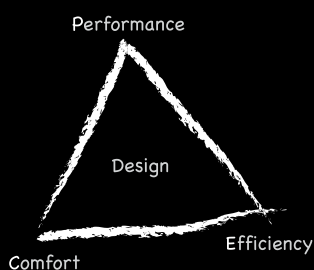

The programme is based on the principle that Performance, Efficiency and Comfort determine the effectiveness of lighting, its impact on the people using it, and its impact on the natural environment. Contrast LED and Qba LED deliver the right light on the right place at the right time.

**Performance:** Providing the best visual effectiveness

- The highly uniform and precisely controlled floodlight beam allows designers to produce applications with good modelling properties, revealing features and patterns in the lit scene.
- The combination of intensive LEDs and versatile attachments enables designers to enjoy a uniform beam with excellent modelling qualities, as well as an infinite number of light effects in a choice of colours and colour temperatures.

**Efficiency:** Conserving energy and effort, reducing CO<sub>2</sub> emissions and waste, providing lighting that is practical and efficient to install, operate and maintain.

- Contrast LED and Qba LED are easy to install and aim. All accessories are supplied ready to fit and to attach to the front frame without the need to open the floodlight body.
- LEDs offer a long operating life as well as good energy efficiency. Lamp replacement is not required, minimising the need for maintenance and reducing the cost of ownership of the luminaire.
- The intensive collimated lenses and optical attachments ensure that there is no waste illumination.
- Unlike conventional light sources LEDs contain no mercury and emit no UV or IR radiation, providing a more environmentally friendly solution.

**Comfort:** giving people satisfaction and stimulation

- RGB LEDs combined with dynamic mixing allow variety in the lit scene, from a calm and relaxing atmosphere to a lively, stimulating environment.
- The discrete design of the Contrast LED and Qba LED floodlights make them inconspicuous by day, blending in with the day lit architecture of a space. Additionally by maintaining current Contrast and Qba designs they can easily be integrated into existing schemes which use conventional Thorn projectors.



### Left

Contrast LED RGB x 3  
Contrast LED warm white

### Right

Contrast LED blue with LR2 refractor  
Contrast LED blue with OMW prismatic glass

Qba LED warm white x 2  
Band Extensive white



# Qba LED light effects

For wall washing applications Qba LED provides an intensive light beam which can be designed with the addition of a refractor with vertical prisms (filter 555B V - elnr 32 196 26).

For an offset application two refractors are offered: with vertical prisms for horizontal light beam orientation (filter 555B V - elnr 32 196 26) and with horizontal prisms for vertical light beam orientation (filter 555B H - elnr 32 196 25).

## Right

Contrast LED warm white with LR1 refractor  
Qba LED cold white x 2  
Band Extensive white

### Measurements made on cold white 6000K version - 18 LEDs

#### Wall washing

Distance 0.3m - Angle adjustment 5°

##### Standard Qba LED



##### 555B V filter



#### Light beam effects

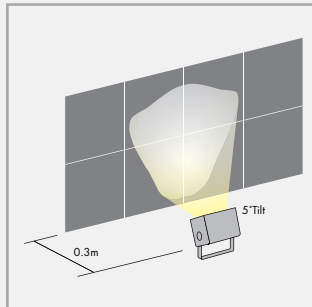
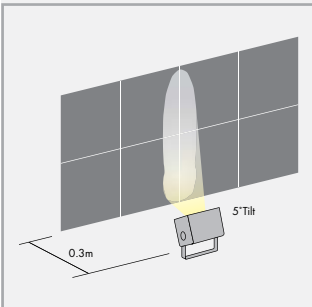

#### Cartesian curves - Absolute values

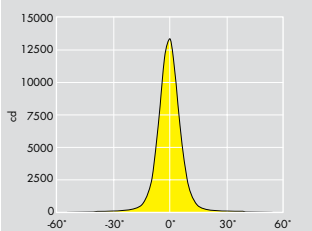

**Qba LED** - cold white 6000K  
Illuminance curve - Without accessories  
Offset 5m - Angle adjustment 0°  
Imax: 13430 cd Flux: 900 lm  
Aperture IMax/2 H: 2 x 5.7° V: 2 x 5.7°

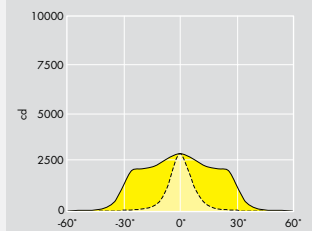

**Qba LED** - cold white 6000K  
Illuminance curve - With filter 555B V  
Offset 5m - Angle adjustment 0°  
Imax: 2940 cd Flux: 800 lm  
Aperture IMax/2 H: 2 x 28.9° V: 2 x 6.5°

#### Isolux curves

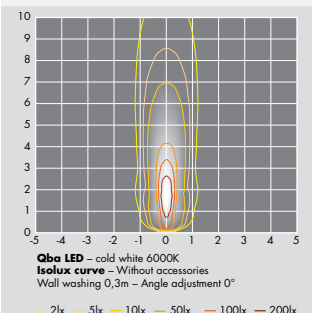

**Qba LED** - cold white 6000K  
Isolux curve - Without accessories  
Wall washing 0,3m - Angle adjustment 0°  
— 2lx — 5lx — 10lx — 50lx — 100lx — 200lx

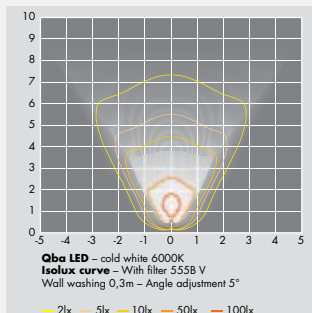

**Qba LED** - cold white 6000K  
Isolux curve - With filter 555B V  
Wall washing 0,3m - Angle adjustment 5°  
— 2lx — 5lx — 10lx — 50lx — 100lx

#### Offset

Distance 5m - Without angle adjustment

##### Standard Qba LED



##### 555B V filter

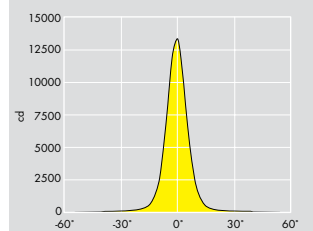
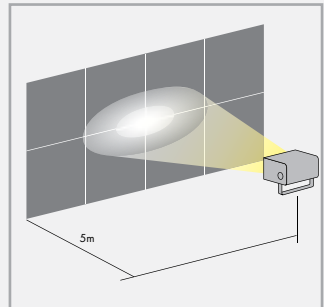
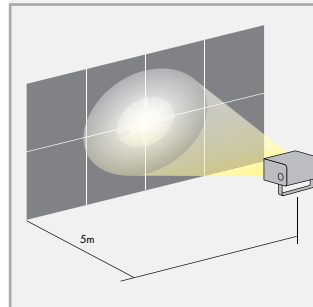

**Qba LED** - cold white 6000K  
Illuminance curve - Without accessories  
Offset 5m - Angle adjustment 0°  
Imax: 13430 cd Flux: 900 lm  
Aperture IMax/2 H: 2 x 5.7° V: 2 x 5.7°

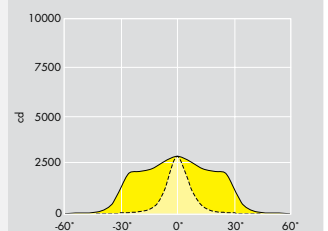

**Qba LED** - cold white 6000K  
Illuminance curve - With filter 555B V  
Offset 5m - Angle adjustment 0°  
Imax: 2940 cd Flux: 800 lm  
Aperture IMax/2 H: 2 x 28.9° V: 2 x 6.5°

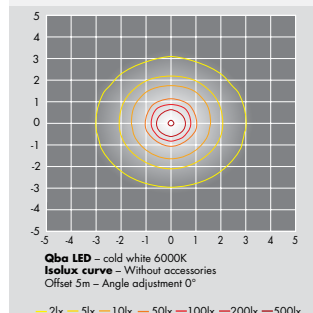

**Qba LED** - cold white 6000K  
Isolux curve - Without accessories  
Offset 5m - Angle adjustment 0°  
— 2lx — 5lx — 10lx — 50lx — 100lx — 200lx — 500lx

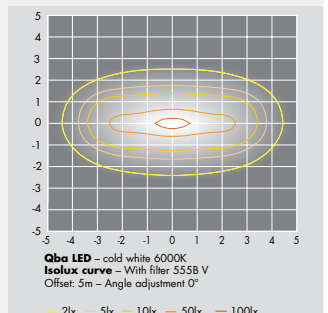

**Qba LED** - cold white 6000K  
Isolux curve - With filter 555B V  
Offset 5m - Angle adjustment 0°  
— 2lx — 5lx — 10lx — 50lx — 100lx





RESTAURANTS

# Contrast LED light effects

Contrast LED presents huge opportunities for the expression of form, colour, contrast, and design – all the things that add a creative dimension to our environment. It provides designers with a way to achieve new and stimulating perspectives.

## Refractors

These can be rotated to align the beam profile to suit the application.

### Measurements made on cold white 6000K version – 54 LEDs

#### Offset

Distance 10m – Without angle adjustment

#### Standard Contrast LED



#### Refractor LR1



#### Refractor LR2



#### Refractor LR3



#### Light beam effects

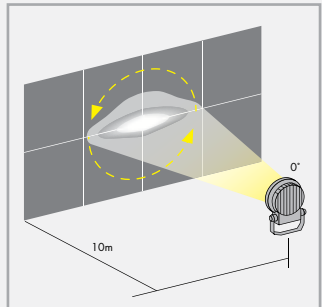
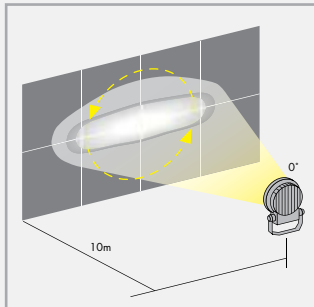
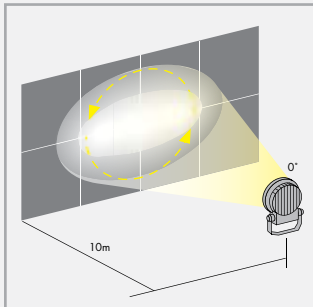
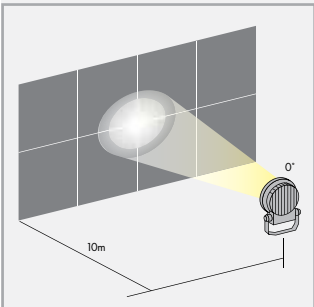

#### Cartesian curves – Absolute values

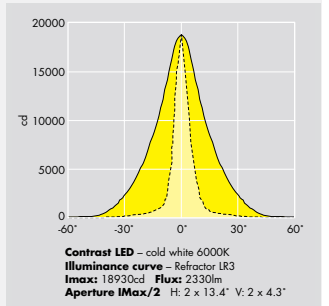
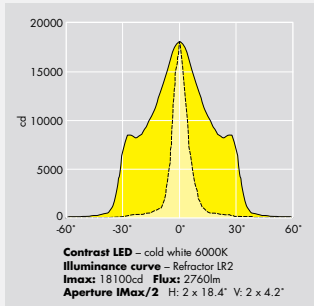
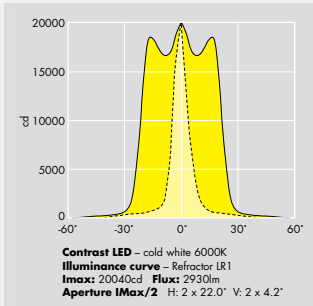
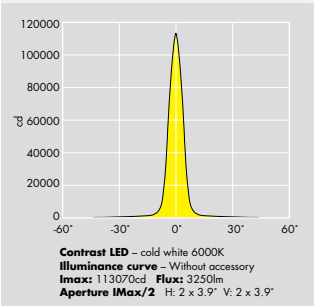

#### Isolux curves

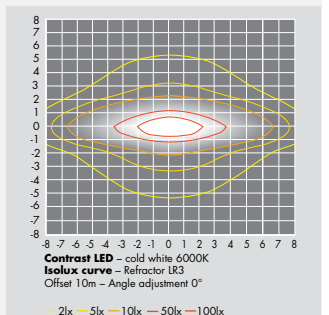
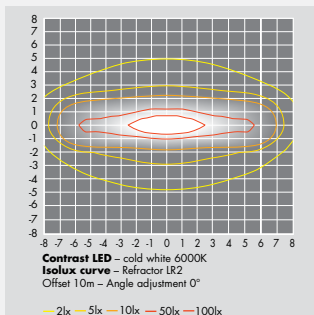
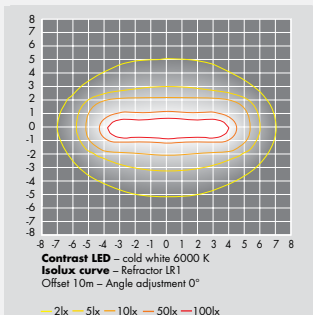
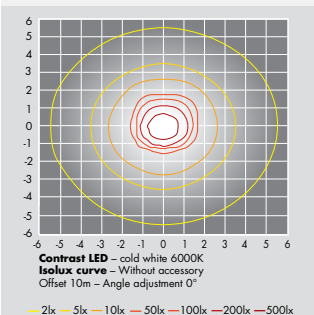

## Prismatic glasses

These can be rotated to give alignment of the beam profile to suit the horizontal or vertical structure.

### Measurements made on cold white 6000K version

#### Offset

Distance 10m – Without angle adjustment

**OMS – Semi-intensive**



**OMP – Semi-extensive**



**OMW – Extensive**



**OME – Super extensive**



#### Light beam effects

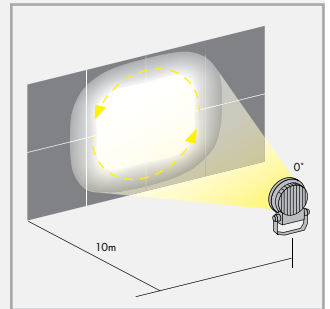
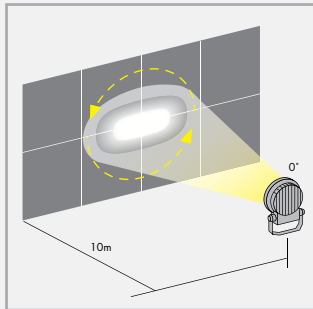
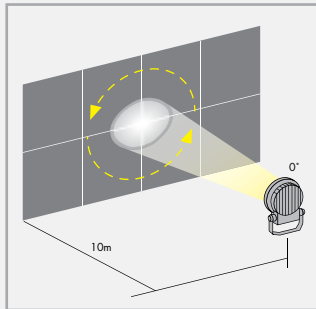
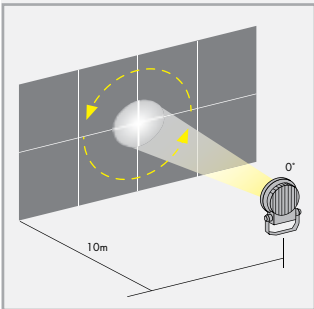

#### Cartesian curves – Absolute values

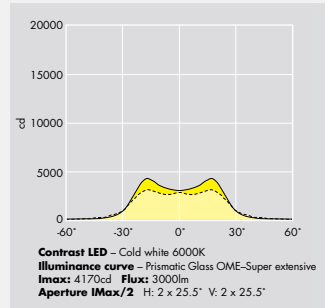
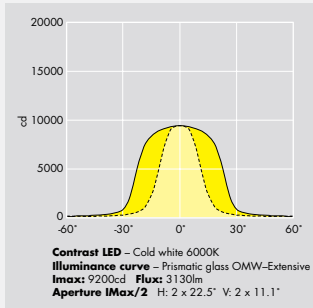
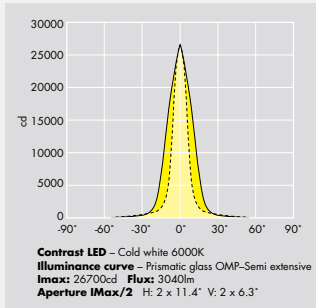
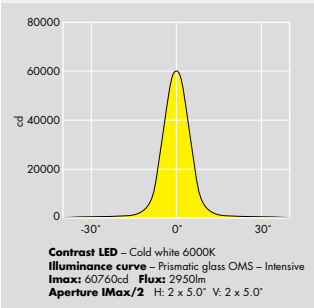

#### Isolux curves

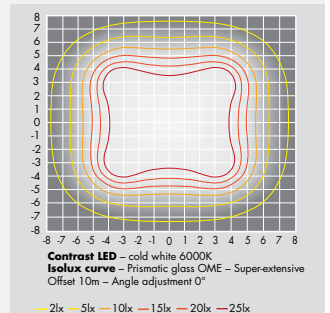
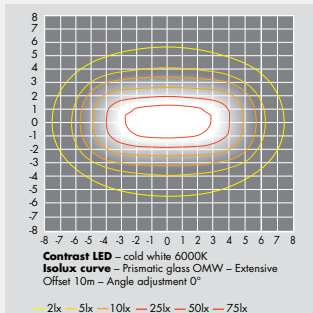
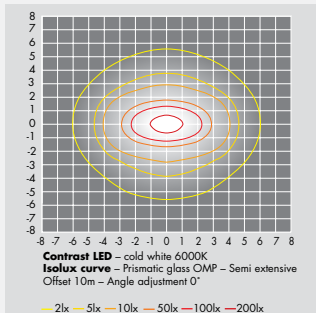
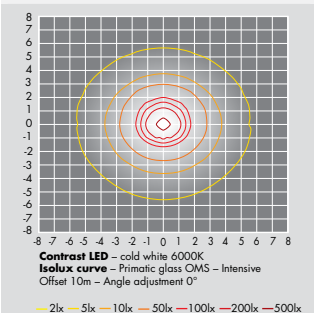

# Contrast LED and Qba LED colour effects

## Colours



### Qba LED monochromatic

319 lumens

287 lumens

870 lumens

293 lumens

### Contrast LED monochromatic

1225 lumens

1078 lumens

2738 lumens

1080 lumens – On request

## Colour temperatures

Two different white versions – warm (3000K) and cold (6000K) support different effects on natural materials or buildings.

A glass chromatic correction filter can be added to the Qba LED or Contrast LED as an easy way to decrease the colour temperature on 6000K and 3000K. The result is 4700K (cold white + filter) and 2700K (warm white + filter) respectively.

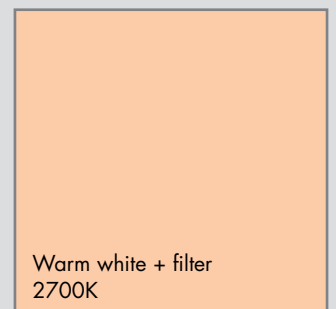
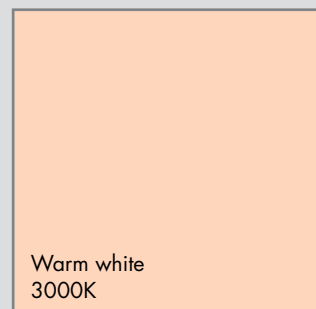
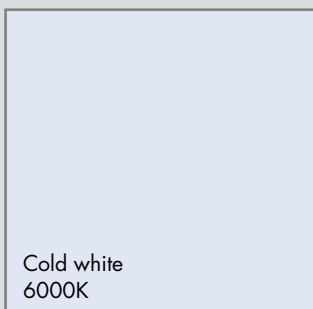

### Qba LED

901 lumens

660 lumens

751 lumens

550 lumens

### Contrast LED

3253 lumens

1984 lumens

2364 lumens

1450 lumens



**Qba LED RGB**

385 lumens

**Contrast LED RGB**

1222 lumens

Values measured with all the LEDs switched on.

The RGB versions are driven by DMX protocol (control system not supplied).



*Qba LED chromatic correction filter*



*Contrast LED chromatic correction filter*



# DMX connection for Qba LED and Contrast LED RGB

If there is no need for special effects or synchronisation between multiple Contrast LED or Qba LED RGB floodlights, an automatic sequence can be played by setting all DMX switches to zero.

For lighting effects, the RGB Contrast LED or Qba LED versions needs a DMX signal provider like the Spectra Memory box (to be ordered separately, see below).

Used in conjunction with the 'Spectrasoft' software, it is possible to create and play scenarios. The Spectrasoft CD is installed on a PC. Once the programme has been installed, it is downloaded to the Spectra Memory box which stores and transmits the data to the projectors. After this the computer is not required except for any programme changes. The DMX signal is sent to the electronic address cards by DM512 cable into the connection box for the Contrast LED or directly into the Qba LED body.

The distance between the memory box (or the other DMX signal provider) and the last Contrast LED RGB/RGBA connection box or Qba LED RGB is maximum 300m with a maximum of 32 floodlights.

They are typical values which need to be confirmed by installer depending upon the project configuration. Even if you use quality cables and DMX line termination, electromagnetic disturbances may occur. To avoid these disturbances use a DMX booster to re-amplify the DMX signal.

If the distance between the memory box and the last floodlight is longer than 300m, a booster to re-amplify the DMX signal is required. The booster will be counted like a fitting. In this case, the maximum quantity of floodlights will be 31 + 1 booster.

The distance between 2 boosters is 300m maximum.

Boosters have 2 or 4 lines to create star wiring. Each line is considered as an independent line which can contain 32 floodlights.

On the final floodlight in the chain, a DMX line termination must be added to prevent the signal 'bouncing back' (into the connection box for the Contrast LED RGB and into the Qba LED rear for the Qba LED RGB).

## DMX Control Ordering Guide

Description	Weight (Kg)	SAP code	
CONT SPECTRA SIGNAL BOOSTER X2 FOR DMX	2.6	96009848	
CONT SPECTRA SIGNAL BOOSTER X4 FOR DMX	3.0	96012407	
CONT SPECTRA DMX LINE TERMINATION	0.1	96012408	
CONTRAST SPECTRA MEMORY BOX (FOR SOFT)	1.7	96253059	
CONTRAST SPECTRA SPECTRASOFT CD	Software	0.1	96012354
CONTRAST SPECTRA CAB DMX512	DMX cable sold per metre	0.1/m	96230866

### Installation without booster and several Contrast LED RGB or/and Qba LED RGB

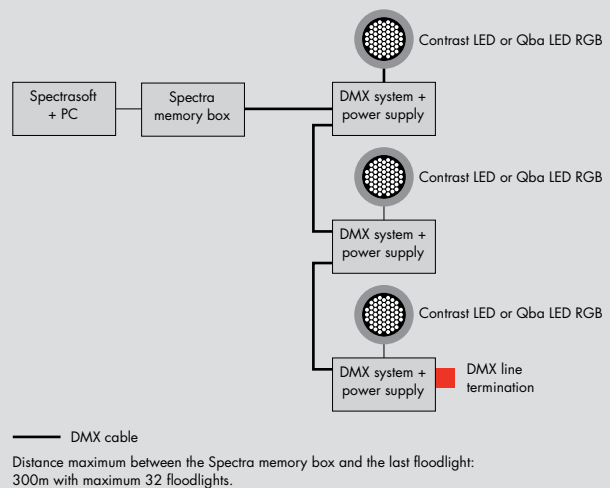

### Installation with 1 booster and several Contrast LED RGB or/and Qba LED RGB

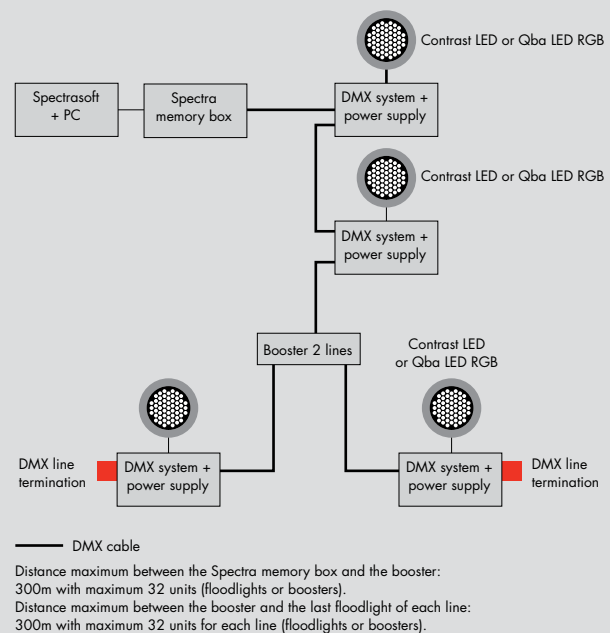

# Qba LED



Monochromatic version



RGB version

## LEDs

Monochromatic: 24W for 18 LEDs  
 RGB: 36W for 8 multichip LEDs

## Materials/Finish

Body, frame and accessories: die-cast aluminium ENAB44100 with textured grey powder coated finish  
 Body screws: stainless steel  
 Attachment retaining screws: nickel plated brass  
 Front glass: toughened glass  
 Alternative RAL colours on request

## Installation/Mounting

Qba LED luminaires are adjustable on a stirrup. Aiming is simplified by an indicator on the body sides, locked via a central 8mmØ Allen screw. Short wall mounted stirrup also available as an accessory. To connect fittings, installers simply open the rear part of the luminaire to access the inside connector.

For electrical connection: cable gland for 6-11 mm diameter cable. An additional cable gland for through wiring is available on request.

For the DMX connection (RGB version only) a DMX cable is required for creative effects. For DMX512 cable the connection requires two 7mm cable glands. Data+, data- and ground are routed to the DMX connector.

## Standards

Designed and manufactured to comply with EN60598  
 Class I electrical  
 Class II electrical on request (monochromatic versions only)  
 IK08/5 N/m impact resistance  
 Ta: 25°C  
 IP66  
 CE

## Specification

To specify state:  
 Compact rectangular LED floodlight for wall washing.  
 Die-cast aluminium body with concealed stirrup. Sealed IP66.  
 With a choice of 6 monochromatic colours (2 white, Red, Blue, Green and Amber) and dynamic RGB employing LED light source with integral power supply for monochromatic versions or power supply plus DMX driver for the RGB version.  
 Other DMX components ordered separately.  
 As Thorn Qba LED.

## Ordering Guide

One code includes the Qba LED with integral power supply for the monochromatic versions or power supply + DMX system for the RGB version

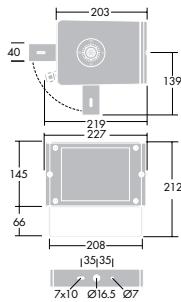

Description	Weight (Kg)	Elnr
<b>Monochromatic versions</b>		
QBA LED 24W 240V 18LED WHI/6000K	6.0	32 119 81
QBA LED 24W 240V 18LED WHI/3000K	6.0	32 119 82
QBA LED 24W 240V 18LED BLU	6.0	32 119 83
QBA LED 24W 240V 18LED RED	6.0	32 119 84
QBA LED 24W 240V 18LED GRN	6.0	32 119 85
QBA LED 24W 240V 18LED AMB	6.0	32 119 86
<b>RGB version</b>		
QBA LED 36W 240V 8LED RGB DMX	5.8	32 119 87





555B H filter



Visor



Louvre



Chromatic correction filter

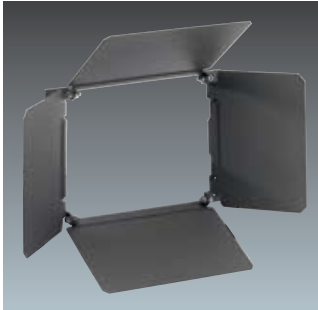

Barn doors



555B V filter



Wire guard

### Accessories Ordering Guide

Description		Weight (Kg)	Elnr
QBA VS	Visor	0.4	32 187 82
QBA WG	Wire guard	0.4	32 187 83
QBA AGS (x4)	Set of 4 barn doors	0.8	32 187 84
QBA LV	Louvre	0.8	32 187 85
QBA FILTER REFR 555B V	Vertical prism	0.6	32 196 26
QBA FILTER REFR 555B H	Horizontal prism	0.6	32 196 25
QBA GL CHROMATIC CORRECTION FILTER	Warmer glass LEE filter 205	0.4	32 119 88
QBA SHORT STIRRUP	Wall stirrup	0.4	32 187 90

# Contrast LED



Monochromatic version



RGB version

## LEDs

Monochromatic: 86,6W for 54 LEDs body inclusive power supply for Whites, Blue and Green. 60W for the Red version (and the Amber version on request). RGB: 51,6W for 36 LEDs body inclusive power supply and DMX driver (and for the RGBA version on request)

## Materials/Finish

Body and frame: die-cast aluminium, textured grey powder coated finish.

Screw-in vents: Gore-Tex®, Polyvent/M12x1.5

Screws: stainless steel

Front glass: 4mm toughened glass

Cable: 1.5m long rubber

H07RN-F 2x1mm<sup>2</sup> for monochromatic versions  
Profilplast CSA type 4x1mm<sup>2</sup> R for the RGB version

(Profilplast CSA type 5x1mm<sup>2</sup> L for the RGBA version)

Alternative RAL colours on request.

Connection box: Grey ABS/PC (Polycarbonate) RAL 7043, material coloured

Gasket: silicon

Cable gland: Brass

Retained screws: stainless steel

Control system: DMX for RGB (RGBA) versions

Accessories (as Contrast R0 except the honeycomb): die-cast aluminium ENAB44100 with textured grey powder coated finish

Retaining screws: nickel plate brass

Front glass: toughened glass

## Installation/Mounting

Contrast LED is delivered complete with body and connection box including the power supply for the monochromatic versions or the power supply/DMX system for the RGB (RGBA) version.

As the floodlight is pre-wired, the body must not be opened in order to preserve the electronic components. The distance between the power supply and the floodlight body is 60mm maximum for the monochromatic versions and 50mm for the RGB version (RGBA on request).

The floodlight is adjustable on a short, narrow stirrup which is fixed to mount by a central bolt hole 18mm diameter, and two 12mm diameter holes at 80mm either sides of centre. Aiming is simplified by an indicator and mark on stirrup, and locked via a central 8mm diameter Allen screw.

Plastic connection box must be opened for connections. Six retaining screws. Connect the Contrast floodlight to the connector in the gear box. Through wiring is supported.

To connect the RGB (RGBA) versions a DMX cable is required if dynamic scenario lighting effects are required. Connect the data+, data- and ground to the DMX connector.

## Standards

Designed and manufactured to comply with EN60598

Class III electrical for the body alone

Class II electrical for the connection box

Class II electrical for floodlight + connection box

IK08/5 N/m impact resistance for the body and the connection box  
Ta: 25°C

IP65 for the body

IP66 for the connection box

CE

## Specification

To specify state:

Shallow round LED floodlight for off set illumination on surface.

Die-cast aluminium body and frame sealed IP65. With a choice of 5 monochromatic colours

(2 whites, Red, Blue and Green)

(Amber on request) and dynamic RGB employing LED light sources

(RGBA on request), with remote connection box with power supply for monochromatic versions and power supply/DMX system for RGB/RGBA versions.

Other DMX components ordered separately.

As Contrast LED.

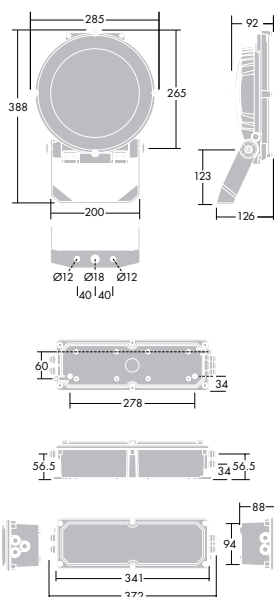

## Ordering Guide

One code includes the Contrast LED with its connection box including power supply for the monochromatic versions or power supply + DMX system for the RGB version (RGBA version on request)

Description	Weight (Kg)	Elnr.
<b>Monochromatic versions</b>		
CONTRAST LED 86,6W 240V 54LED WHI/6000K	6.3	32 260 85
CONTRAST LED 86,6W 240V 54LED WHI/3000K	6.3	32 260 86
CONTRAST LED 86,6W 240V 54LED BLU	6.3	32 260 87
CONTRAST LED 60W 240V 54LED RED	6.3	32 260 88
CONTRAST LED 86,6W 240V 54LED GRN	6.3	32 260 89
<b>RGB version</b>		
CONTRAST LED 51,6W 240V 36LED RGB DMX	7.0	32 260 90



OMS – semi-intensive prismatic glass



LR1 – medium wide refractor



Wire guard



Chromatic correction filter



OMP – semi-extensive prismatic glass



LR2 – wide refractor



Adjustable anti glare louvre



Barn door



OMW – extensive prismatic glass



LR3 – narrow refractor

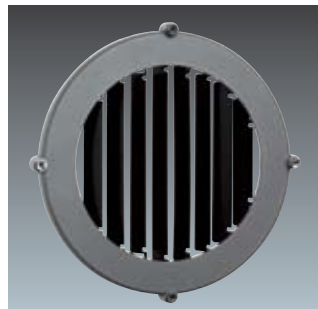

Fixed louvre



Visor



OME – super extensive prismatic glass

### Accessories Ordering Guide

A wide selection of attachments can be fixed on the Contrast LED front. The accessories can be superimposed and used with prismatic glasses or refractors to offer a variety number of light effects. All adjustments can easily be made on site.

Description		Weight (Kg)	Elnr.
CONT R0 GL/FR S/S SINT (OMS)	Semi-intensive symmetrical	1.0	32 260 07
CONT R0 GL A/S SINT (OMP)	Semi-extensive asymmetrical	1.0	32 260 08
CONT R0 GL A/S EXT (OMW)	Extensive asymmetrical	1.0	32 260 09
CONT R0 GL S/S XEXT (OME)	Super extensive symmetrical	1.0	32 260 10
CONT R0 LR1	Medium wide refractor	1.0	32 260 04
CONT R0 LR2	Wide refractor	1.0	32 260 05
CONT R0 LR3	Narrow refractor	1.0	32 260 06
CONTRAST R0 GL CHROMAT CORRECTION FILTER	Warmer glass LEE filter 205	1.0	32 260 91
CONT R0 WG	Wire guard	1.0	32 260 17
CONT R0 LV	Fixed anti glare louvre	0.7	32 260 14
CONT R0 LV/AJ	Adjustable anti glare louvre	0.7	32 260 11
CONT R0 AGF	Spill light controller	1.0	32 260 18
CONT R0 VS	Visor	0.4	32 260 15
CONTRAST C0/R0 AGS (x1)	Barn door (x1)	1.0	32 195 07

# THORN

Lighting people and places

## Hovedkontor

### Thorn Lighting AS

Strømsveien 344

1081 Oslo

Tlf 22 82 07 00

Fax 22 82 07 01

Ordrefax 22 82 07 49

## Drammen

Thorn Lighting AS

Øvre Eiker vei 14

3048 Drammen

Tlf 32 20 14 82

Fax 32 20 14 81

## Bergen

Thorn Lighting AS

Kanalveien 105B, 5068 Bergen

Postboks 133 Kristianborg,

5822 Bergen

Tlf 55 20 06 60

Fax 55 20 03 60

## Trondheim

Thorn Lighting AS

Granåsveien 1

7048 Trondheim

Tlf 73 89 44 00

Fax 73 89 44 02

info.no@thornlighting.no

**[www.thornlighting.no](http://www.thornlighting.no)**

Thorn Lighting utvikler og forbedrer sine produkter kontinuerlig. Alle beskrivelser, illustrasjoner, tegninger og spesifikasjoner i denne utgivelsen presenterer kun generelle opplysninger og danner ikke noen form for kontrakt. Vi forbeholder oss retten til å endre spesifikasjoner uten forhåndsvarsel eller offentlig kunngjøring. Alle varer som leveres av selskapet leveres i følge våre generelle kjøpsvilkår. En kopi av disse er tilgjengelig ved forespørsel. Alle mål er i millimeter og vekt i kilo, bortsett fra hvis annet er angitt.

**Utgivelsesnr: 446 (NO) Utgivelsesdato: 07/09**